

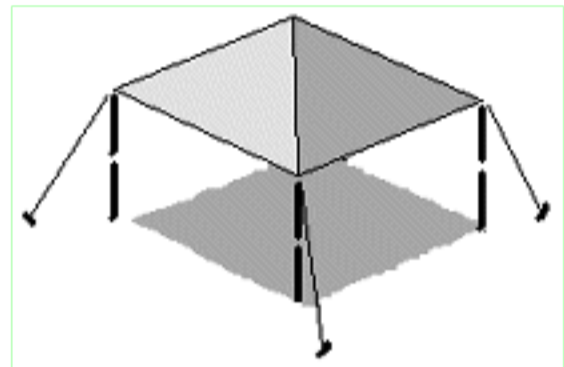

Some configurations you can use with your Beachshadow - you may discover more.

with windbreak
page 4/5

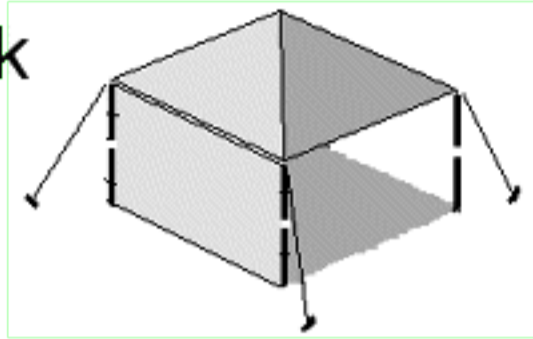

8 vertical poles
page 4/5

6 vertical poles

page 3

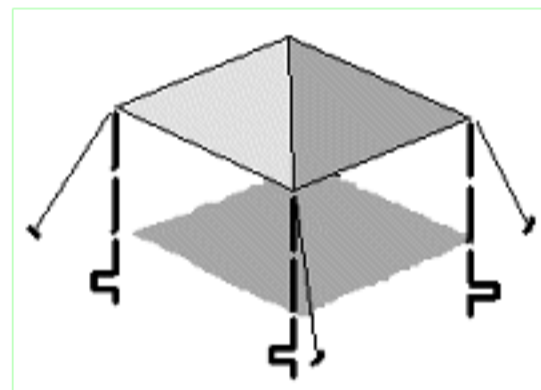
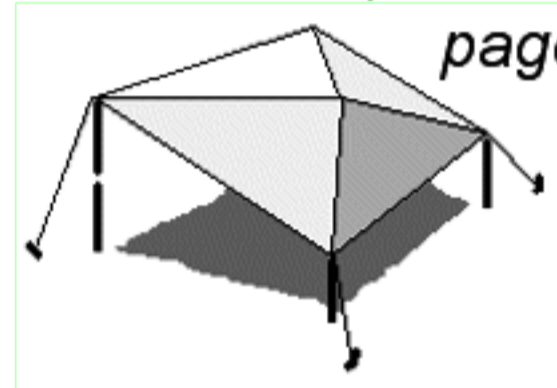

on soft ground/
firm sand, page 2

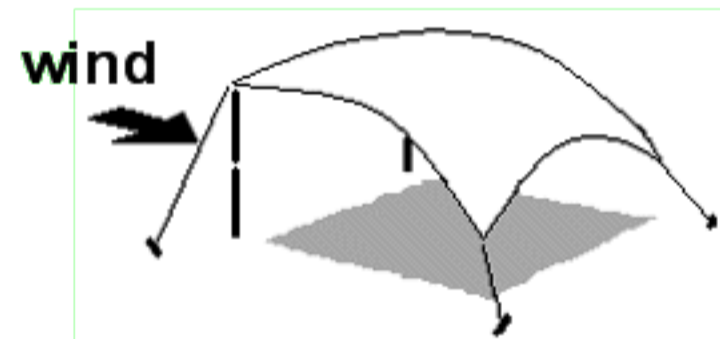

windy day, page 7

Windbreak only

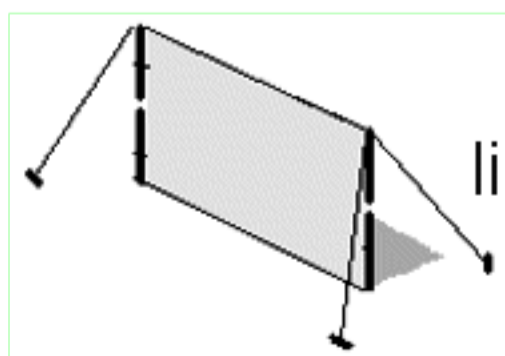

light wind,
page 5

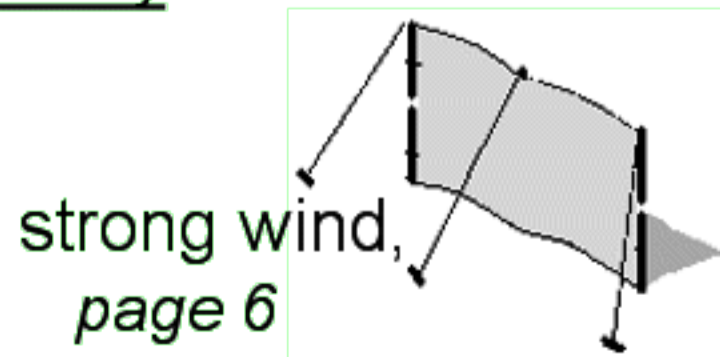

strong wind,
page 6



These instructions are intended for you to get more out of your Beachshadow kit, and are a summary of information available on our website.

Beachshadow is about the UV cover and the protection it offers you. As with any large material area, it is susceptible to wind, so always ensure that the guy lines are secured to the sand/ground even on days with no wind.

We hope that you and your Beachshadow get along well, we know it will provide the Ultra Violet shade protection that you have purchased it for. We welcome feedback and issue a newsletter twice a year covering UV facts, customer feedback and updates to Beachshadow as the product evolves. Please e-mail us from the website www.beachshadow.com to register for this newsletter.



Contents

- Page 2** Components, soft ground/firm sand options
- Page 3** Six pole configuration
- Page 4/5** Assembly Instructions for Basic Set-up
- Page 6** Windbreak alone, Optimum use of sand peg
- Page 7** Canopy Set-up on windy days
- Page 8** Summary of possible configurations

For more information, visit www.beachshadow.com

This product should be constructed by a responsible adult.
Beachshadow Ltd cannot accept any liability for injury caused whilst using this product

Windbreak alone on windy days

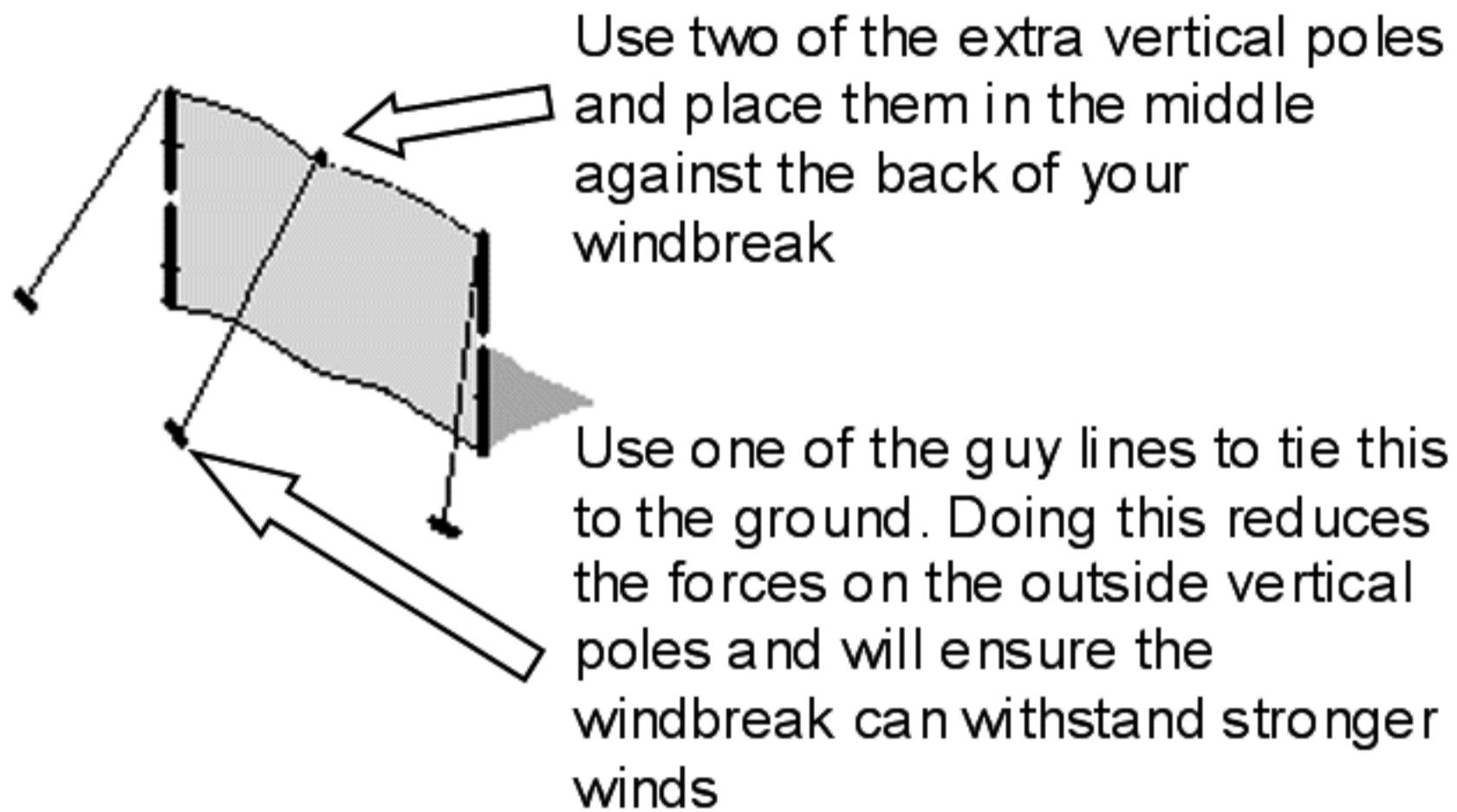

Optimum use of sand pegs

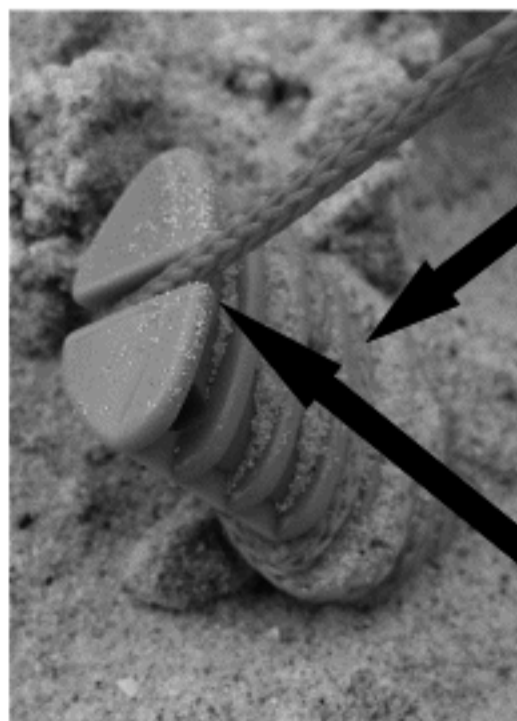

Wrap excess string around peg

Place peg all the way into the sand

Ensure guy line goes over the top of the peg

Six Pole Configuration

This is a good configuration for when the sun is nearer to the horizon. You only require 6 vertical poles

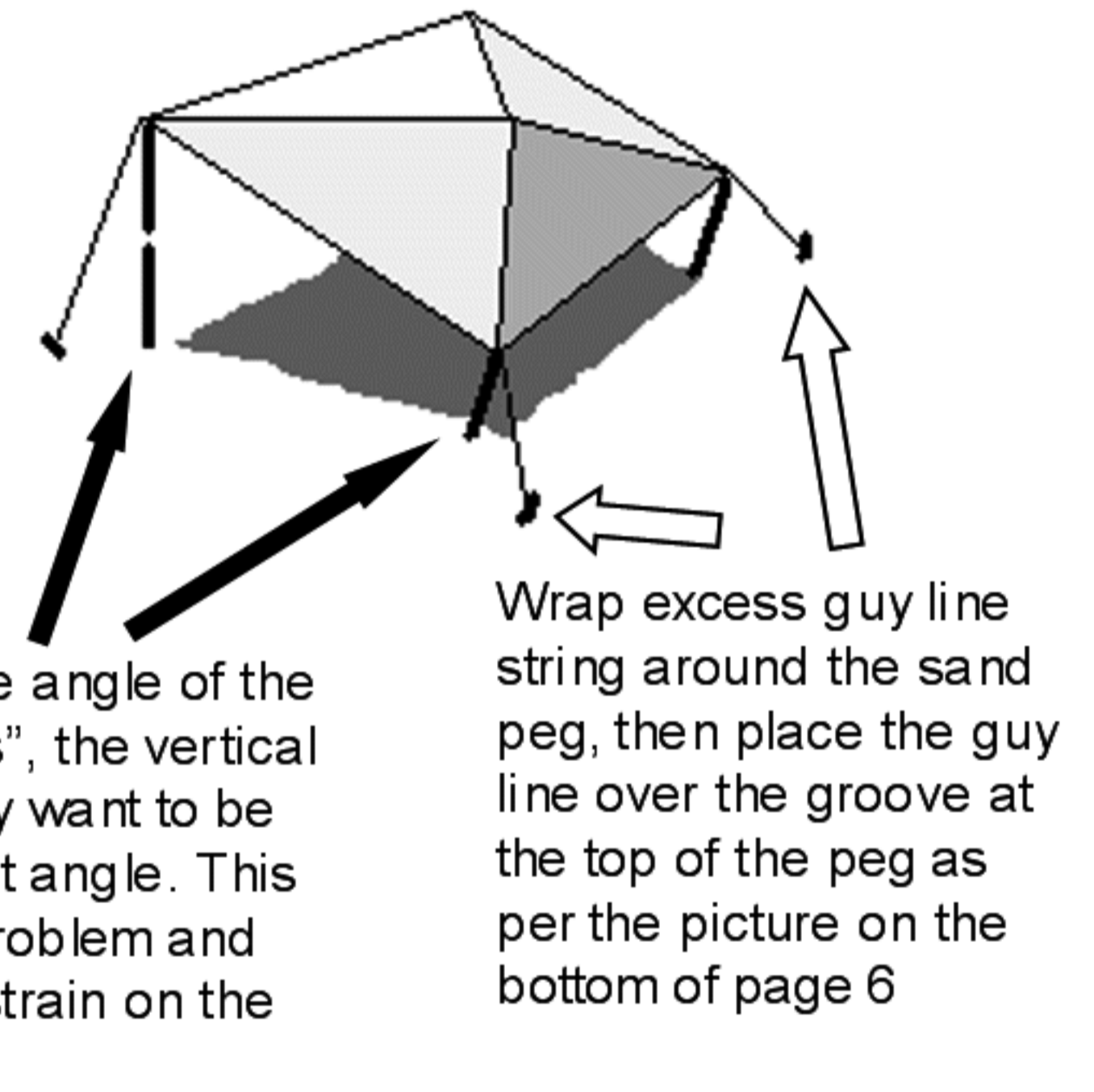

Contents of your Standard Beachshadow kit

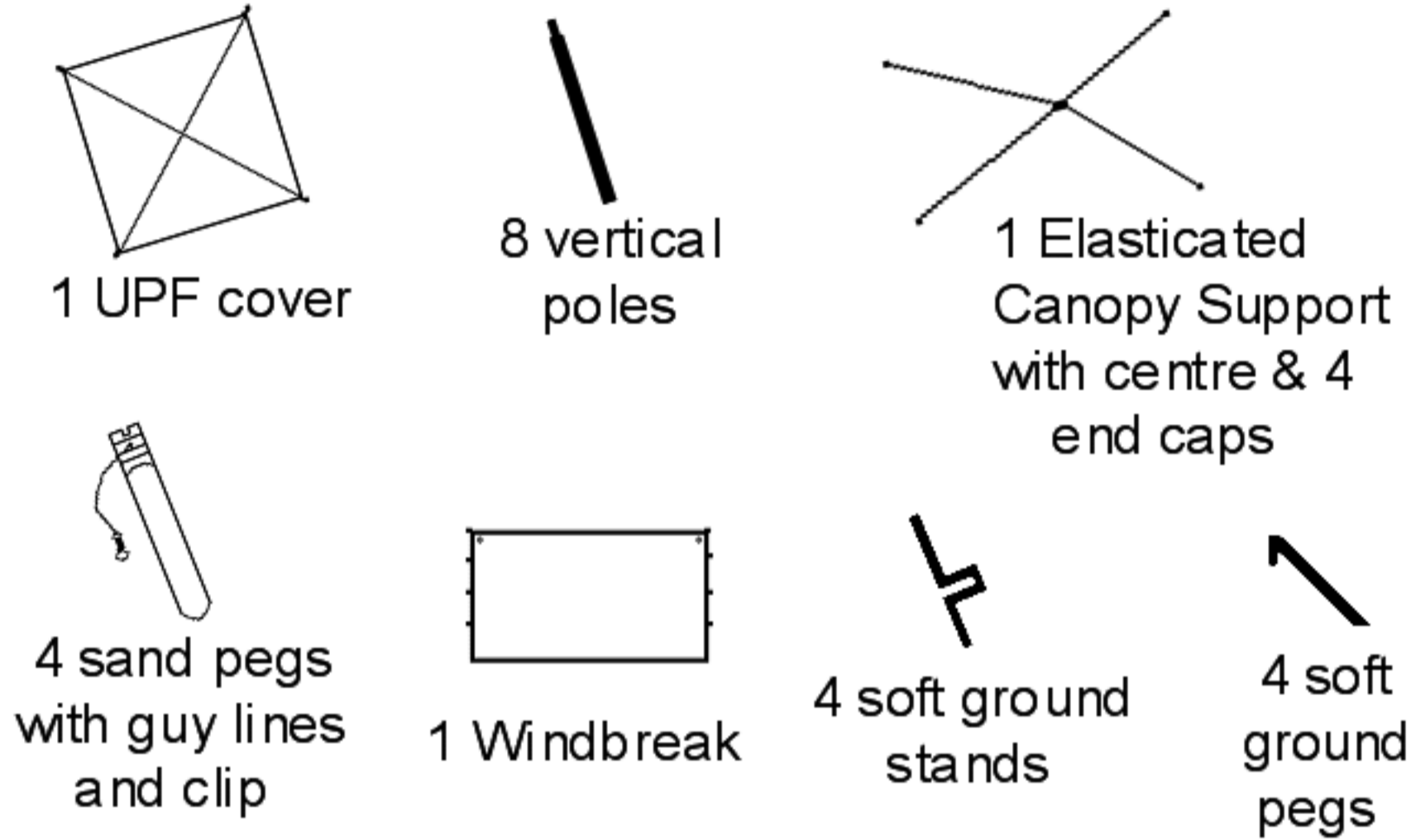

Soft Ground/Firm Sand Options

The soft ground stands are supplied as an option to avoid mud clogging up the vertical poles, they are also handy when using Beachshadow on a shingle beach

Place pole onto stand



Canopy Set-up on windy days

On windy days, such as a strong sea breeze, Beachshadow is best used without the canopy support

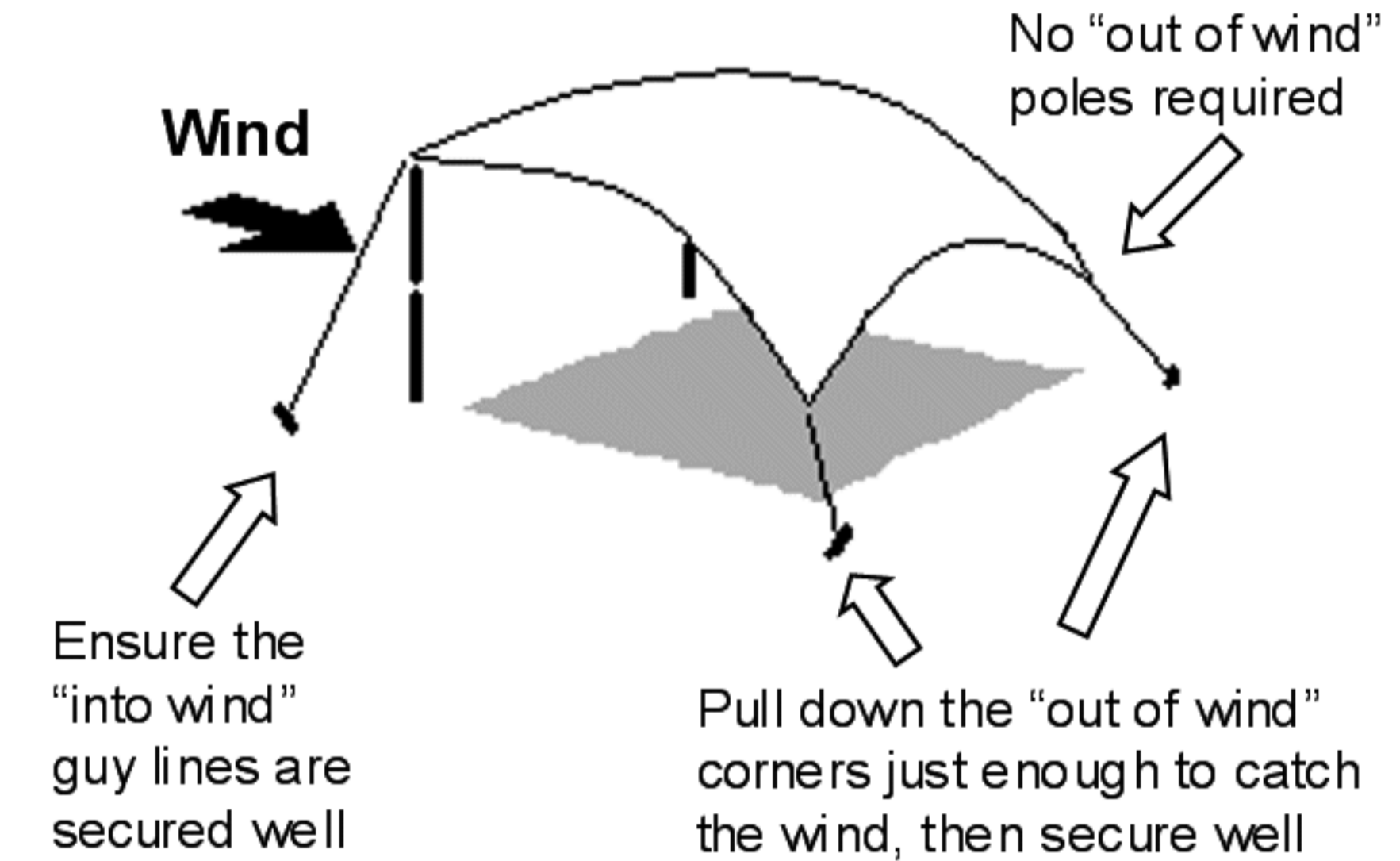

If the breeze has picked up during the day with the Canopy Support in place, you can easily remove the Canopy Support to get the cover into this configuration

The windbreak cannot be used in this configuration

Assembly Instructions

For further information, additional parts and other set-up options, please visit our website.

4

1. Assemble the Elasticated Canopy Support

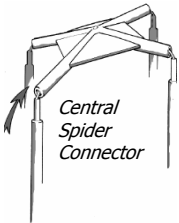

Connect together the Poles which are elasticated around the Central "Spider Connector".

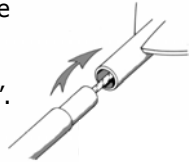

2. Position Beachshadow

Place the assembled Canopy Support in position, on the ground.



3. Assemble the Uprights

The Uprights are supplied in two halves. Connect the pieces to make 4 Uprights.

Push an Upright into the ground (for hard ground, please see below) next to each corner of the Canopy Support.

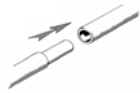

4. Raise the Canopy

Lift the Canopy Support onto the Uprights.

Ensure the Arrow is pointing upwards.

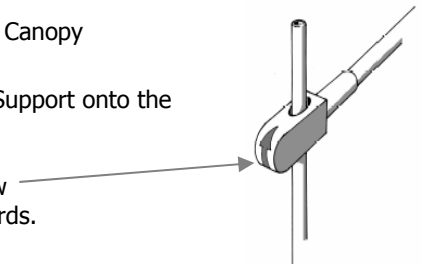

5. Position the Guy Lines and Pegs

Hook one end of a Guy Line over each Upright.

Partially push the Peg into the ground, leaving the Guy Line slack.

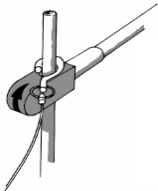

6. Fit the Canopy

Lift the Canopy over the Frame. Start at the windward corner. Remove the Guy Line from the Upright and position the Canopy Eyelet, then attach the Guy Line to the Canopy itself.

In windy conditions, wrap guideline once around the vertical pole, like this....

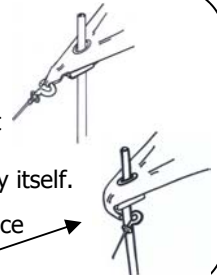

7. Tensioning the Guy Lines

Ensure the Guy Lines and Uprights are in alignment.

Tighten the Guy Lines and push the Pegs fully into the sand, as per page 6.

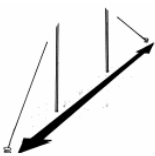

8. Shadow

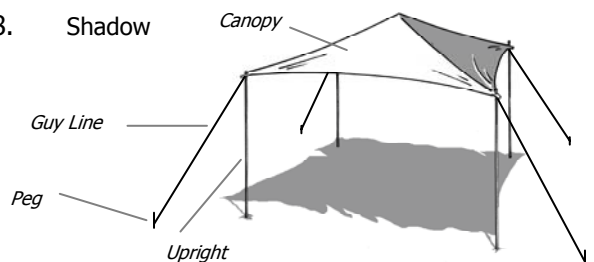

5

Adding the Windbreak

Place Windbreak Eyelets over the top of the Pole and secure Windbreak to the Pole using the Velcro Straps.

Using the Windbreak by itself

Erect two sets of Vertical Poles about 2 metres apart. Place Windbreak over the top of the Poles and secure the Poles with Guide Strings. Secure Windbreak to the Pole using Velcro Straps.

Using the Hard Ground Stand

Push the Hard Ground Stand into the ground and slot the upright onto the exposed end of the Stand.

